

INTRODUCTION

FTR series of switching power supplies of regulated and insulated voltages are targeted to industrial electrical devices.

Built with advanced technology, they are appropriated to be installed in electrical panels since they have the reliability and robustness demanded from these environments. **FTR** series has two models: **FTR** is targeted to smaller installations with lower power demands; **FTR-60** model is much more powerful and allows energy supply to bigger installations with many devices. Both of them can be attached to traditional 35 mm DIN rails.

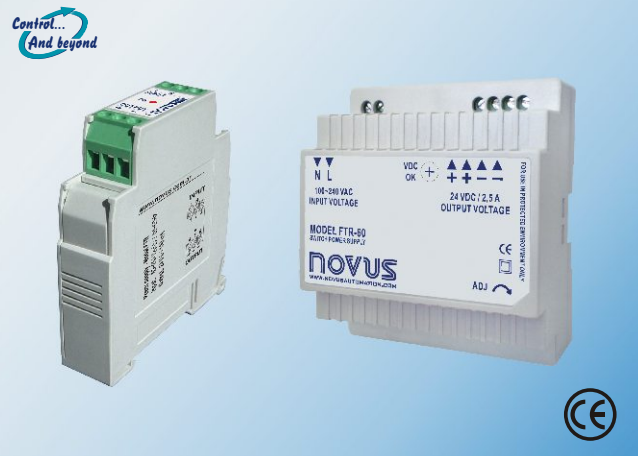

FEATURES & SPECIFICATIONS

- Input Voltage (Input): 100~240Vac / 50~60 Hz.
- Output Voltage (out): 24 Vdc; ± 2 %.
- Output Power: 3 W (FTR); 60 W (FTR-60).
- Efficiency: > 85 %.
- Input/Output Isolation: 600 V.
- Operating Environment: -20 to 50 °C.
- Humidity Environment: 30 to 80 % UR.
- Indoor use.
- Protection: IP40.
- Installation: DIN rail of 35 mm.
- Connection wire cross section: 0,14 to 1,5 mm².
- Screw tightening torque: 0,8 Nm.
- Terminals covering in polyamide.
- Output Voltage Adjustment range: < 10 % (FTR-60).
- Short-circuit protection; overload and overvoltage protection.

DIMENSIONS FTR

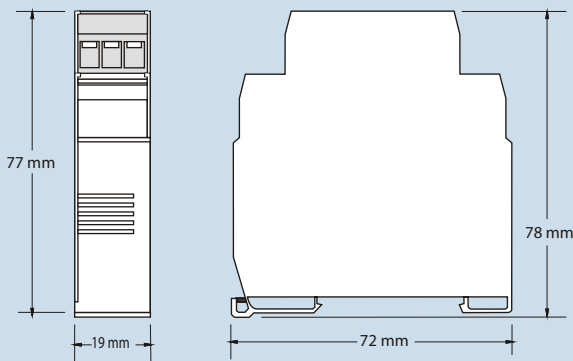

DIMENSIONS FTR-60

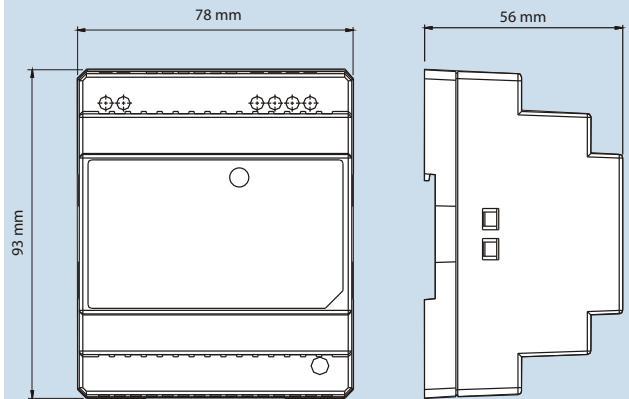

BLOCK DIAGRAMS

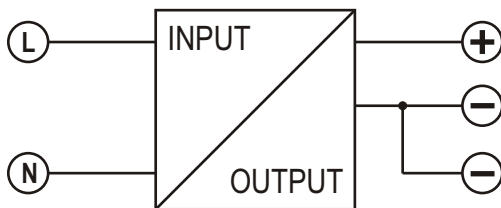

FTR

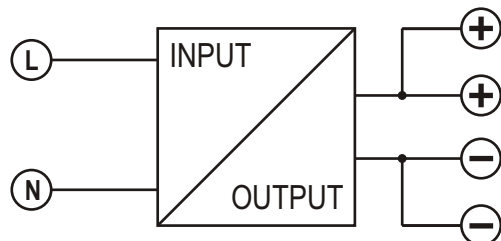

FTR-60